

AQUATICA™

Digital



OPERATING MANUAL FOR THE AQUATICA PRO DIGITAL HOUSING FOR THE NIKON D90

PRODUCT # 20063 / 20063 DB / 20063 KT / 20063 KM

Thank you for having selected the AQUATICA Pro Digital Camera Housing System for your underwater photography.

The AQUATICA Pro Digital Housing is the result of a long and continuing relationship with the most demanding underwater photographers in the world. Each housing is handcrafted, quality checked and pressure tested to a 300 feet equivalent by a small group of specially trained individuals, each of whom takes the utmost pride and satisfaction in offering the best underwater camera housing in the world.

The Aquatica Pro Digital Housing was designed for optimum technical and optical performance and to provide easy and efficient underwater access to essential functions and controls of the Nikon D90 DSLR.

This manual assumes that the User is already familiar with the Nikon D90 camera. If not, please read the Nikon instruction Manual before attempting to use the housing.

With basic care and maintenance, your AQUATICA housing will give you a lifetime of enjoyment and satisfaction in producing underwater images.

Please read this manual carefully before using your housing for the first time and note that: wherever cited the right hand is your right when using the housing.

SAFETY PRECAUTIONS:

Improper transportation handling or use of this housing might cause a flood or malfunction.

Please read and follow the following precautions:

- Store and transport the housing in a sturdy, shock proof container and avoid travelling with the camera mounted inside the housing as impact forces especially on the external push buttons will be transferred to the camera.
- When travelling by air, either remove the port or open the housing.
- Never change a port or open the housing in a location where sand or similar foreign material might come in contact with an O-ring.
- Use of accessories or modifications and alterations unauthorized by the manufacturer may result in flooding or poor functioning of the controls.
- Be careful when opening the housing as the pressure buildup inside the housing will exaggerate the force of the latch spring. Keep fingers away from the path of the latches.
- Whenever changing ports or O-rings, perform a simple seal test with out the camera inside.
- Avoid scratching the acrylic or glass ports and windows.
- Make sure that all ports remain properly attached before rinsing the housing, especially when rinsing without a strobe make sure the Bulkhead connector is sealed with its plug.
- Never attempt to operate the camera in autofocus mode with the lens mounted focus gear engaged with the housing gear.
- The main O-ring seals should be maintained and cleaned on a regular basis. Read and follow the *Care and Maintenance* section on this manual.
- Ensure that the spring loaded secondary lock is properly engaged on the latches to prevent their accidental opening.

AD90

AQUATICA™
Digital

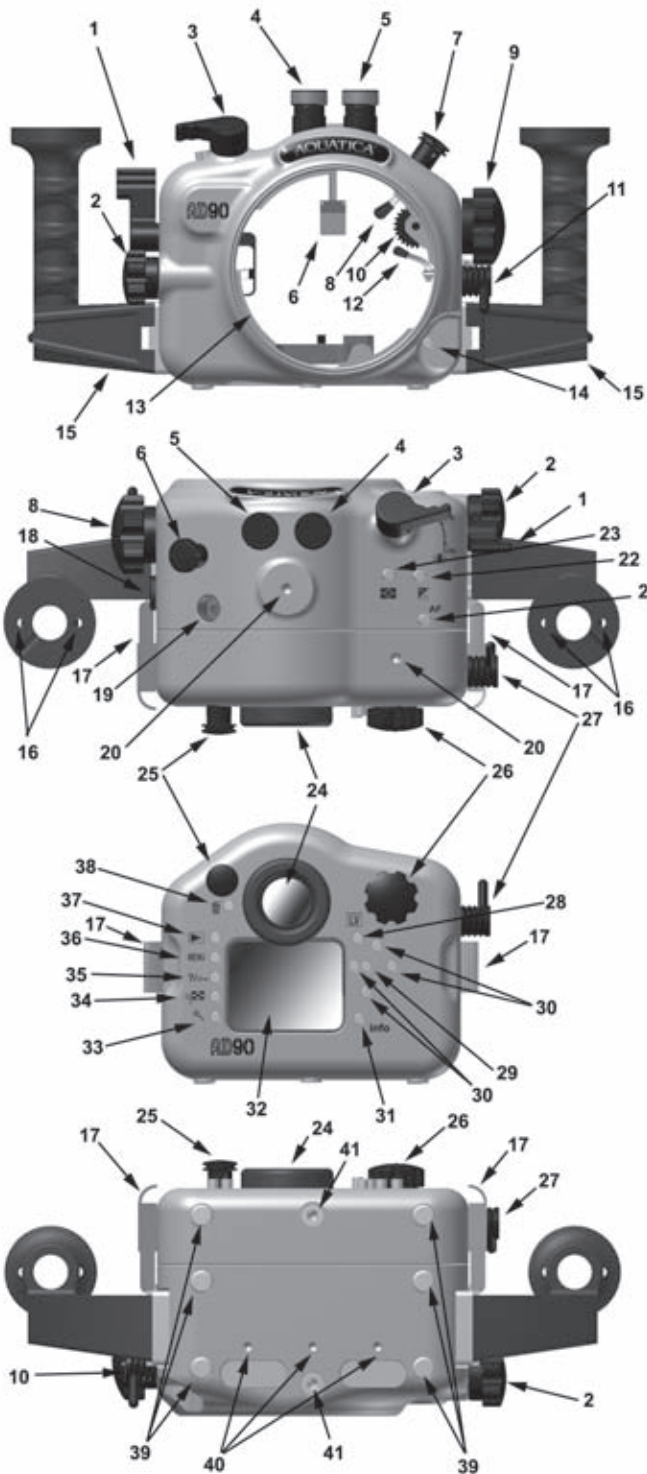

- 1- Shutter Release lever
- 2- Sub-Command Dial knob
- 3- Power Switch/Illuminator lever (* info)
- 4- Main Bulkhead Connector
- 5- (Optional) Secondary Bulkhead Connector
- 6- Hot shoe connector
- 7- Flash Mode/Exposure Compensation knob
- 8- Flash Mode/Exposure Compensation lever
- 9- Focus/Zoom Control knob
- 10- Focus/Zoom Control pinion gear
- 11- Lens Release knob
- 12- Lens Release knob lever
- 13- Bayonet Flange
- 14- Port Release mechanism button
- 15- Grips (x2)
- 16- Grip's Accessories mounting holes (1/4"-20)
- 17- Latches (x2)
- 18- Lateral Accessory Bulkhead port
- 19- Exposure Mode Dial port window
- 20- (2x) Accessory mounting hole (1/4"-20)
- 21- AF mode selector button/Reset button
- 22- Exposure Compensation/Reset button
- 23- Metering pattern mode selector/Format button
- 24- Viewfinder Eyepiece
- 25- Shooting Mode selector knob
- 26- Main Command Dial knob
- 27- AE/AF LOCK & AF-ON lever
- 28- LIVE VIEW activating button
- 29- OK button
- 30- Multi Selector (Joy Pad)
- 31- Info Display button
- 32- Rear LCD window
- 33- Qual (Image Quality/Size)/ Playback Zoom.
- 34- ISO (ISO Sensitivity) Thumbnails button
- 35- WB (White Balance)/Help/Protect button
- 36- Menu button
- 37- Playback button
- 38- Delete button/Format button
- 39- Rubber Anti Skid pad
- 40- Accessories mounting holes (x3)
- 41- Sacrificial Anodes (x2)

CONTROLS IN DETAIL

1. SHUTTER RELEASE LEVER: Pulling the shutter release lever back part way activates the camera meter and auto focus. Pulling the lever back all the way fires the camera.
2. SUB-COMMAND INPUT / APERTURE KNOB: Rotates clockwise and counterclockwise. Use alone or in combination with other controls to select or set various camera functions or modes. In "Manual" the exposure mode controls the aperture settings (see camera manual).
3. POWER SWITCH / ILLUMINATOR KNOB: Rotate to switch camera on or off or to engage illuminator, this can also activate the INFO function (see CSM menu section of your camera).
4. MAIN BULKHEAD CONNECTOR: To connect Flash Sync Cord. (Manual Nikonos Type by default other option available on request).
5. OPTIONAL SECONDARY BULKHEAD CONNECTOR: For Flash Sync Cord. (Nikonos Type by default other option available on request).
6. HOT SHOE CONNECTOR: connects the camera to the Flash Bulkhead. Slide this Connector into the camera Hot Shoe. When detaching do not pull the cord as this might damage the electrical connections.
7. FLASH MODE & EXPOSURE COMPENSATION: rotate to engage and use sub-command dial for selecting the flash exposure compensation or the main commands dial for selecting the different mode of flash synchronization.
8. FLASH MODE & EXPOSURE COMPENSATION LEVER: rotate via knob (#7) to press on the flash mode & flash exposure compensation button of the camera, remember to disengage once you finish selecting your mode or compensation
9. FOCUS/ZOOM KNOB: Turning allows manual focus of a single focus lens or rotation of the zoom mechanism of a lens.
10. FOCUS/ZOOM PINION GEAR: Engages and operates the focus or zoom gear attached to the lens.
11. LENS RELEASE KNOB: activates the lens release button on the camera allowing easy removal of the lens.
12. LENS RELEASE KNOB LEVER: Applies pressure on the camera lens lock button
13. BAYONNET MOUNTING FLANGE: allows the mounting of different ports and extension rings on the housing.
14. PORT RELEASE MECHANISM BUTTON: Press down to release the locking mechanism when installing or removing a port or extension.
15. HAND GRIPS (X2): Left and right grip allowing the mounting of strobe arms and accessories.
16. GRIP'S ACCESSORIES MOUNTING HOLES: Two 1/4"-20 TPI holes on each grip are ready to accept TLC Base Brackets or TLC Base Ball for strobe arms or accessories.
17. LATCHES: Two heavy duty latches with safety locks to protect against accidental opening.
18. LATERAL ACCESSORY BULKHEAD CONNECTOR: For additional accessories or control connector
19. EXPOSURE MODE DIAL PORT WINDOW: allows viewing which mode is selected when rotating knob (#25)
20. MOUNTING HOLE FOR ACCESSORY: a 1/4"-20 TPI hole is supplied to accept a TLC accessory or TLC base ball for mounting a strobe arm or a modeling light.
21. AF MODE SELECTOR/RESET: press to select the appropriate AF mode via the main command knob (#26), to reset camera setting to default hold down along with exposure compensation button (#26) for more than two seconds.
22. EXPOSURE COMPENSATION BUTTON: Press to engage the Exposure compensation control [+/-]. Rotate the Main-Command knob to set the desired exposure compensation value. The value will appear in the Top LCD panel and in the Viewfinder. This button when pressed along with QUAL (# 34) button will reset the camera shooting parameter to its default position.
23. METERING PATTERN SELECTOR / FORMAT: Push and rotate main command dial clockwise or counter clockwise to select the metering mode, choice are; Spot, Center Weighted or Matrix metering options. This button when pressed at the same time as the delete button (38) will format the card inside the camera.
24. REMOVABLE VIEWFINDER: A full view of the illuminated camera viewfinder displays all necessary information. This viewfinder be removed and replaced with optional Aqua View Finder for a larger displayed image.
25. SHOOTING MODE BUTTON: rotate the knob to the selected exposure mode, recommended mode are manual & aperture priority,

* Auto Mode and Preprogrammed Auto Mode should be avoided for underwater photography.

CONTROLS IN DETAIL, CONTINUED

26. MAIN-COMMAND INPUT KNOB: It rotates clockwise and counterclockwise. It can be used alone or in combination with other controls to select or set various camera functions or modes. Refer to camera manual for in depth use.
27. AE / AF LOCK: Lock the auto focus / auto exposure or use for activating the AF-ON button according to preference. See page 200 of you Nikon Manual for more info (this button Can also be re assigned to other functions via CSM menu option f4 of your camera).
28. LIVE VIEW: this button activate the Live View function of the camera and allows the user to view through the rear LCD window, as well when OK button (#29) is pressed it will activate the record mode of the video feature of this camera.
29. OK: Pressing this button will validate your menu options, when pressed down in the Live View this will engage the video recording function.
30. MULTI SELECTOR BUTTONS: These buttons have multiple uses. They allow the selection of the focus area, in the menu mode, they are used to scroll up or down and left to right to choose from your menu selection and they are used as well in the delete mode.
31. INFO BUTTON: This button will activate the rear LCD and display all pertinent shooting information, this function can be accessed through the ON/OFF/Illuminator knob (see shooting tip on page 9)
32. MONITOR DISPLAY WINDOW: allow viewing of menus, information and images
33. IMAGE QUALITY/SIZE SELECTOR CONTROL/ PLAYBACK ZOOM: Press to access the different image quality available on the camera; use in conjunction with main and/or sub command dial control knobs. Pressing this button in the playback mode will magnify the image.
34. ISO CONTROL / THUMBNAIL PLAYBACK BUTTON: Press to select ISO, use in conjunction with main command dial control (# 26). In play back mode press to display images in "contact sheets" of 4 or 9 images or for zooming out.
35. WHITE BALANCE / PROTECT BUTTON: Press to access white balance functions, use in conjunction with subcommand dial (#2) to select mode and/or main dial controls (# 26) to the preferred attributes of the selected mode.
36. MENU BUTTON: Press to activate menu display, scroll using multiple selector buttons and select using enter button.
37. PLAYBACK BUTTON: Press to activate the monitor and review images.
38. DELETE BUTTON: Press to delete images, use multiple selector buttons to select and press the enter button to delete, can also be used in conjunction with the mode selector button (24) in order to format the card inside the camera.
39. RUBBER ANTI SKID PADS: Four rubber pads are provided to protect the housing and preventing it from sliding on wet decks.
40. MOUNTING HOLES: Three 1/4" X 20 holes are provided for mounting strobes trays or accessories.
41. SACRIFICIAL ANODES: (2X) zinc anodes are installed to protect your housing against salt water corrosion; theses are made to deteriorate easier than the other strategic part of your housing, hence the name sacrificial anodes. These anodes need to be replaced by the user as needed.

The *Aquatica Digital* housing serie is issued from the world's most technologically advanced underwater housing lineage, ergonomically designed to place all the essential camera controls under your finger tips and features the following:

- A. A port locking mechanism to prevent accidental rotation of the port or extension mounted on the housing
- B. A Lens Lock Release control that will activate the lens release button of camera from the outside of the housing.
- C. A quick release tray, allowing fast and easy removal of camera.
- D. Large ergonomic and easy to operate controls for most of the manual and computerized camera functions.
- E. A flexible strobes connector circuitry that allows switching from manual to TTL easily.
- F. The following controls can be easily manipulated underwater:
 - Live view access
 - Video recording
 - Mechanical shutter release.
 - Shutter speed through the Main-Command Dial
 - Aperture through the Sub-Cmd Dial
 - Focus / Zoom
 - AE-L/AF-L & AF-ON access
 - LCD panel illumination & information display.
 - Top LCD windows
 - Metering system selector
 - Exposure mode (Mode)
 - Exposure Compensation
 - Focus Area Selector
 - ISO sensitivity
 - Delete button access
- G. A complete selection of bayonet mounted ports including an 6", 8" and 9.25 diameter dome, two flat ports, various extension rings to preserve the image quality of your Nikon Mount AF lenses.
- H. A complete line of lens gears including Auto/Manual focus selector gears and related accessories.

PREPARATION OF THE HOUSING

1. Attach Grip Bracket to the housing:

The housing comes with two Grips for both right and left hand grips which should be installed on the sides of the housing with the supplied screws and Allen key. Occasionally remove the grips and lubricate the screws (see Care and Maintenance: of the housing.)

Depending on which strobe system you are using, you can mount the necessary shoes or brackets onto the 1/4"-20 threaded holes on the top of the hand grips. The AQUATICA TLC strobe arm system is recommended.

There are also three (3) 1/4"-20 threaded holes on the bottom of the housing that can be used for various mounting application trays. As well two (2) holes on front and rear of the housing for mounting accessories.

Mount your strobe(s) or iTTL converter and connect the sync cord to the main housing's strobe bulkhead. Be sure to read the section titled "Care and Maintenance: of the O-rings."

2. Lubricate the Main O-ring Seal:

Before use, carefully inspect the Main O-ring seal from in its groove on the front half of the housing to confirm that it is free from scratches or foreign material. Lubricate the O-ring with a light coat of silicone grease.

When replacing the O-ring place the entire O-ring over the O-ring groove and start by pushing the O-ring in the corners. Work your way around the O-ring making sure the O-ring is snugly sitting in the groove.

For proper handling and maintenance of O-rings be sure to read the section titled "Care and Maintenance: of the O-rings."

PREPARATION OF THE PORTS

1. Select the correct port:

Depending on whether you've decided to shoot macro or wide angle photography, you will be installing either a flat Macro Port (product # 18426 or 18428), or a Dome Port (Product # 18405, 18407 or 18409). See *lens chart for the suggest port and accessories*.

Macro Port Extension Rings: the Macro Ports will accept the AF-D & AF-S Micro-Nikkor 60mm lens without extension. If you intend to use a longer lens you will require an additional extension ring. These extension rings fit between the Macro Port and the housing to provide the extra space necessary for the longer lens.

Dome Port Extension Rings: When using a wide angle or zoom lens, the Dome Port may require the uses of an extension ring to closely match the optical center of both the dome and the lens.

In order to reduce glare, maximize contrast and offer physical protection to the dome, the use of a dome shade is highly recommended. See *lens chart for the suggested dome shade*.

A comprehensive list of the lenses supported and their required extensions and/or accessories is supplied at the end of this manual. For the latest updated version of this lens chart, you can refer to the Lens Chart on www.aquatica.ca

2. Clean the port:

Dirt, grease or fingerprints on the port especially on the inside, can adversely affect the quality of the image. Acrylic ports should be cleaned with plastic cleaner and the glass ports should be cleaned with lens cleaner. For more details be sure to read the section titled "*Care and Maintenance: of the Ports.*"

3. Lubricate the port O-ring seal:

Before using the port, remove the O-ring on the rear of the port and lightly coat it with silicone grease. For more details be sure to read the section titled "*Care and Maintenance: of the O-rings.*"

PREPARATION OF THE LENS

Depending on the lens used, there are a number of gear options possible. Using the right gear (s) and correctly mounting them on the lens is very important for a smooth housing operation. Follow the installation directions included with each gears carefully. Since the aperture control is achieved through the Sub-Command Dial, the use of AF types of lenses is mandatory.

A comprehensive list of the lenses supported and their required gears is supplied at the end of this manual. For the latest updated version of this lens chart, you can refer to the Lens Chart on www.aquatica.ca

Notes: If the camera is set in manual focus a focus gear must be mounted on the lens. If you are using a zoom lens with a zoom ring the camera must be on auto focus, also note that if using a dome port you may need to install a closeup diopter on the lens to correct the minimum focusing distance of the lens so that it will be able to focus on the virtual image created by the dome. See *lens chart for the suggested diopter, if required for your lens/port combination*.

Gear installation:

Mount the focus gear over the focus ring of the lens.

(a) For Slip-on gears (gears without mounting screws): Slide the gear over the lens and align the gear with the front of the lens focusing ring.

(b) For gears with mounting screws: Tighten the three set screws evenly. Tighten each screw approximately ½ a turn working around the gear until all the three (3) screws are tightened, and the gear is concentric with the lens body.

CAUTION: Do not over-tighten these screws, as this might bind the lens, thus restricting the rotation of the focus ring and/or damaging the lens. Conversely under-tightening these screws might cause the gear to slip or loose alignment.

Rotate the focus ring several times to make sure it moves smoothly and the gear does not slip before closing the housing

WARNING: If the lens is a not of the AF-S type, never attempt to operate it with the camera in autofocus mode and with a mounted focus gear engaged. This might cause serious damage to your camera or to the lens.

Zoom lenses: When using a zoom lens, the gear should be mounted on the zoom lens control. The housing focus control then becomes the zoom control. Focusing of lens is achieved by using the camera's autofocus system.

CAMERA PREPARATION AND INSTALLATION

1. Set the Focus Mode Selector to the M position on both the housing and the camera.
2. **Important Note:** prior to installing the camera in the housing, remove the camera strap, “D” Clips and/or any object that might obstruct installation or get in the way of that attach the strap should be removed or tucked away
3. Make sure the ON / OFF / ILLUMINATOR knob (key # 3) is in the ON position and that the lens lock lever is in the proper UP position
4. Remove the saddle from the housing and carefully place the camera on it and ensure the camera is properly installed and aligned as follows:
 - a) The camera is properly aligned and secured against rotation or movement.
 - b) Align the Tripod Socket of the camera with the mounting screw. Tighten the mounting screw securely while ensuring that the camera position is not altered. set arresting block as per drawing at right.
 - c) Slide the quick release tray back into place as per drawing at right.

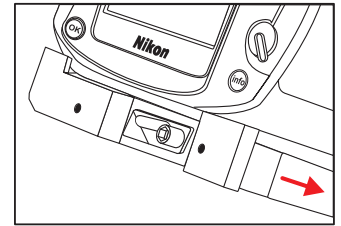

CLOSING OF THE HOUSING

Once the camera is secure on the saddle inside the front half of the housing, simply:

1. Slide the housing's hot shoe connector onto the hot shoe base of the camera, as seen in drawing at right.

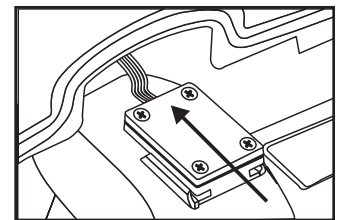

Before closing the housing always ensure that:

1. The main O-ring on the front half of the housing is clean, lubricated and properly seated for a positive seal.
2. The sealing surface on the rear half of the housing is clean and free from any scratches or physical damage.
3. All cords or wires are tucked in so that they do not interfere with the closing of the housing.

To close the housing simply:

- i. Join the front and rear halves of the housing using the two dowel pins at the bottom of the housing as a guide.
- ii. Hold the housing with both hands and look around the sealing surface to ensure that the O-ring remained properly seated and that no cords, wires or “D-rings” are caught between the edges.
- iii. Close the two sides latches simultaneously, reverse the process to open housing

CAUTION: if you feel any resistance as you attempt to close the latches, do not force the closure. Check for an obstruction and try again.

- iv. Verify that the safety locking mechanisms of the latches are properly engaged to avoid any accidental opening.

LENS INSTALLATION

With the camera inside the housing, install the lens prepared with the gears through the port opening in the front of the housing. Ensure that the lens mounted gears are properly installed and aligned. Rotate the focus / zoom control knob to ensure that the gears are properly meshed, do not grind and that their rotation is smooth.

Note: To avoid damaging the auto-focus mechanism of the camera when using standard AF type lenses with focus gear, you should always set the Focus Control to "M" Manual for testing the proper meshing of a focusing gears. this procedure is not required with AF-S type lenses.

CHANGING A LENS (REMOVING A LENS)

The lens mounted gears may restrict the view and ease of access to the lens release button of camera. The AQUATICA Digital Housing features a Lens Release Lever (key # 11) that is designed to trigger the lens release button of camera to allow easy removal of lens.

To remove a lens, simply rotate Lens Release Lever (key # 11) to press the camera lens release, hold and turn the lens clockwise.

MOUNTING THE PORT

Before mounting the Port on the Housing always ensure that the port O-ring is clean, lubricated and properly seated in its groove and that the sealing surface on the Housing is clean and free of physical damage.

The *AQUATICA Pro Digital* Housing System features a locking bayonet mount (#14). To mount the port or extension ring simply:

1. Place the housing on its back on a soft steady surface.
2. Place the port or extension ring inside the main port of the housing. Align one of the four alignment notches with the opening of the housing.
3. Place your hands on opposite sides of the port or extension ring.
4. Push with even force on both sides of the port or extension ring until you feel it snap into place. Make sure the bayonet is completely inside the housing.
5. Finally press the port lock button down, turn the Port clockwise until it stops and then release the port lock button. Do not force it. If there is too much resistance take the port off, check the O-ring and retry.
6. Check to ensure for the proper seating and sealing of the port or extension and that it is safely locked on the housing.

Note : It is recommended that you familiarize yourself with this mount by trying it without the camera, this will allow you to see the inside view of the bayonet mount and of the ports or extension rings in the housing.

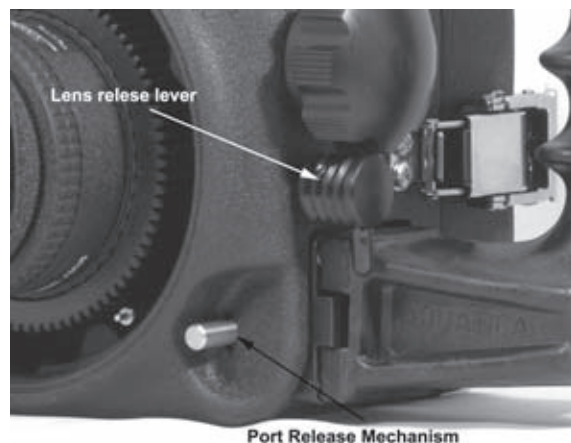

MOUNTING AND ATTACHING FLASHES

Depending on which strobe system you are using, you can mount the necessary shoes or brackets or Base Ball onto the threaded holes on the top of the hand grips. Use of the Aquatica TLC Strobe Arm System is recommended.

There are also three 1/4"-20 threaded holes on the bottom of the housing that can be used for various mounting applications. For example, A mounting tray can be fitted on the bottom of the housing. A 1/4"-20 threaded hole on top of the rear half of the housing will accept an Aquatica bracket or Base Ball that can hold a small dive light or a strobe arm.

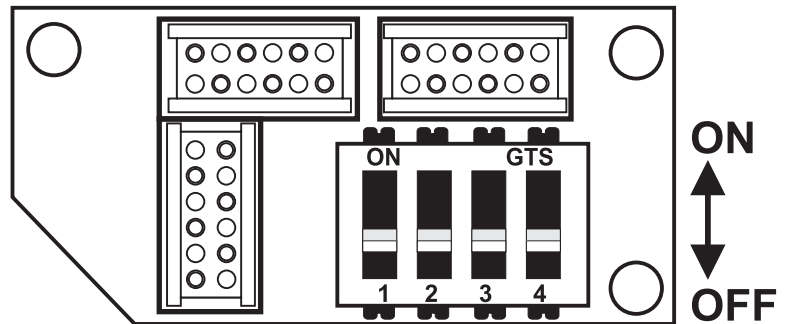

Internal switch board circuit:

Your Aquatica D90 Digital housing is supplied with two Nikonos type connectors which are in turn connected to a switch board circuit that will allow you to choose between full manual exposure or iTTL (an external converter or single housed flash is required). Optional Ikelite bulkheads connectors are also available.

When preparing the sync cord be sure to lubricate the O-ring on the sync cord's connector with a light coat of Aquatica O-ring lubricant, Also advisable is to put a light coat of O-ring lubricant on the threads of this connector.

Your Nikon Digital camera design does not allow two flashes to be connected directly to the camera, whether in a housing or on dry land, this is due to the wireless approach used by them for triggering the additional flashes, when two flashes or strobes are connected directly to the camera, iTTL will stop to function and a camera freeze is likely to happen.

On your housing you will find two bulkhead connectors, the main connector is wired through a switch board that will allow you to take full advantage of iTTL exposure, the secondary connector is always in full manual configuration and cannot be used for iTTL operation. By default you housing is delivered with the switch board set to full manual, if the iTTL exposure is desired then it can be made in either of two methods:

- 1) By using a single flash from Nikon or other brand (that is iTTL compatible with your camera) in a underwater housing connected with a TTL cord to the main connector of your Aquatica housing.
- 2) By using an external iTTL converter connected to the main connector of your Aquatica housing, one or two underwater strobes with TTL cords which are then connected to this converter, (check strobe and converter manufacturer for compatibility).

Set up instruction for iTTL operation

Using the tip of a pen push the switches 1, 2 & 3 to the ON (up) position, this will activate the connections on your main bulkhead connector allowing TTL communication between the camera and the housed flash or iTTL converter.

Set up instruction for manual operation

All switches must be in the OFF (lower) position, in this case all iTTL connection are disabled and only the ground and sync are left active, this will allow two under water strobes or housed flashes to be connected directly via the main and secondary bulkhead.

TAKING A PICTURE

Following are the basic techniques. For more information and advanced photography please study the Nikon D90 instruction manual.

NOTE *The command and sub command function can be inverted, refer to the "CSM" section of your menu, select " f Controls", select "f5 command dial", select "change Main/Sub", select On and confirm by selecting OK. this allow the aperture to be selected by the command knob in the rear and the shutter speed by the front sub command knob. allowing the users to conveniently position vital controls at their fingertip.

1. Rotate the Mode dial button (key # 25) and select the desired exposure mode, the chosen mode will appears on both the Viewfinder (key# 24) and Top Mode dial port window (key # 19).
Useful and recommended Exposure Mode are: Programmed Auto (P) (with no flash attached), Aperture Priority Auto (A) or Manual Exposure (M).
2. Control of Auto Exposure compensation (key# 22) is achieved by pushing down the button to engage compensation function, select proper parameter by using the main command knob.
Note: When using a flash, it is recommended that the camera be preset to the Single Frame Drive or there is the possibility that the camera will fire before the flash can recycle.
3. Push the Metering Pattern button (key# 23) and select the metering system symbol you wish to use: 3D Matrix, Center-Weighted or Spot, in the LCD panel.
4. Pull the Shutter Release Lever partially back. This will activate the camera's meter and autofocus system.
5. If using manual focus use the Focus Knob (key # 9) on the housing or on the flat port to focus.
6. If using the Manual mode adjust the Main Command Knob (key # 26) to set the shutter speed and or sub-command (key # 2) to adjust aperture.
7. Pull the Shutter Release Lever (key # 1) the rest of the way until the camera fires.

Shooting tip:

1) It is possible in the D90 Custom Setting Menu to program the ON/OFF/ILLUMINATOR (#3) switch to activate the INFO function, this will allow the user to view the complete shooting data on the rear LCD, making modification to the camera exposure a simple task, this function is also accessible from the rear INFO dedicated button, but given the convenient location of the ON/OFF/Illuminator lever it makes sense to access it in this manner.

To program this function, first select the CSM menu, go to (f) controls section, select f1 switch, then select the both feature, press OK to accept, your camera is ready to use in this manner.

2) The lever in the rear right portion of the housing (key #27) can be used to access the AE-L / AF-L or the AF-ON functions as well as many custom variant of AF lock and activation via the f4 CSM options, careful reading of the camera manual (page 200) will yield valuable information on your personal potential preferences.

NOTE : Select the proper focus mode with the selector button (key # 21) on the housing. For more detailed information concerning the operation of the different focus modes consult the Nikon instruction book for the D90.

USING THE HOUSING

Whenever changing ports or O-rings, it is highly advisable to perform a simple seal test without the camera inside. Strapping a weight to the housing and lowering the unit to a depth of 30 to 50 feet of water for at least 10 minutes will assure you that the seating of the new port or o-ring is proper. This test, though time consuming and often considered unnecessary, may save your camera equipment from irreparable water damage. The housing is now ready for the dive.

CAUTION: Never jump into the water with the housing. It is best to have the system handed to you after you have made your entry, or have it lowered to you on a rope. Make certain that ropes of other equipment stay clear of the system.

When photographing, be sure to respect the environment. Avoid damaging marine life or manipulating sea creatures to obtain a pleasing photo. The housing is slightly negatively buoyant so that you can lay it down on the bottom, but avoid laying it on living coral or other delicate marine life.

Changing the memory card

Always take care to thoroughly dry the housing before opening it to change memory card. Wipe the housing off with a dry towel. If possible it is suggested that the housing be blown dried by directing an air nozzle around the main o-ring before opening.

Rest the housing on its front with the lens facing down, be careful to protect the port surface, release the two side latches simultaneously. Lift the rear part of the housing and place it in a secure location. This minimizes the possibility of any residual water falling into the housing and on to the camera when the housing is opened or damage to the sealing surface.

TRANSPORTING THE *AQUATICA Digital* housing

Store the *AQUATICA Digital* housing in a sturdy, shock proof container. When travelling by air, remove or loosen the port. This allows for equalization of the air pressure inside the housing to the external air pressure. Failure to do so may cause serious damage to the acrylic ports. Avoid travelling with the camera mounted in the housing. If you must do so, remove the lens as external pressure can damage the camera.

CARE AND MAINTENANCE

Of the housing:

After each and every salt water dive, your housing system should be soaked or rinsed in fresh water. The housing system should soak in fresh water for at least 30 minutes. During this soaking period reach into the water and operate all the controls several times.

Be sure to remove the housing's main o-ring and clean it after every use. Refer to Maintenance: Of the O-rings. To ensure that the hand grips won't fuse on to the housing due to the exposure to salt water, it is also a good practice to occasionally remove the hand grips. Clean and lubricate the bolts with a small amount of WD-40.

WARNING: Use WD-40 carefully, sparingly and only on metal to metal surfaces. WD-40 can damage the acrylic on the ports, the optical surfaces on lens as well as the O-rings.

Of the Ports:

Care should be taken with the Dome Port and Macro Port to avoid scratches on the lens surface. The acrylic port is softer than glass so minor exterior scratches are often unavoidable. However, since the indices of refraction for acrylic and water are almost equal the scratches will not seriously impair image quality. Internal scratches (air side) must be avoided as they do not fill in with water and will affect the quality of the image.

Clean the dome using only products recommended for cleaning acrylic and a soft lint free cloth. Dust on the interior surfaces of the port can be removed with a soft camel hair brush or a blower brush. Caution must be taken when using aerosol devices as not to spray the lens material with the liquid propellant as this may seriously affect the optical properties of the port. Use of pressurized air from a dive tank is not recommended, the force of the air stream may easily dislodge a port or O-ring. It is advisable that ports should be removed and serviced after every dive.

Of the Latches:

The two latches of the *AQUATICA Digital* are designed to have a locking action to prevent accidental opening. Always ensure that the locking mechanism is secure. Watch for the build-up of corrosion or salt residue around the latches. This will appear as a white material. Lubricate the latches with a small amount of WD-40 to remove the corrosion or salt residue build-up.

Of the O-Rings:

The O-rings that need to be maintained on a regular basis are the main housing O-ring and the O-ring on the lens port. The main O-ring should be cleaned on a daily basis and the port O-ring should be cleaned daily or each time the port is changed.

Of the sacrificial anodes:

The two anodes attached to the bottom parts of the housing are there to prevent corrosion due to electrolysis, as time goes they will deteriorate and need replacement, contact your dealer for replacement (parts # 19220).

TO SERVICE O-RINGS ON THE HOUSING MAIN O-RING, PORTS AND EXTENSION RINGS

1. Remove the O-ring. It is important never to use a sharp instrument when removing an O-ring as this may damage the O-ring groove or the O-ring itself. A bobby pin or edge of a credit card works well.
2. Once the O-ring is removed, it should be examined for damage. Check to make sure that the O-ring is free of nicks and cuts and that it retains its original round profile. O-rings that appear to be damaged should be discarded immediately and replaced with new O-rings.
3. Rinse the O-ring with fresh water and dry it with a clean lint free cloth.
4. Clean the O-ring groove (where the O-ring sits) with a Q-tip. Be sure to remove any lint the Q-tip may leave behind. Inspect the groove for damage.
5. Wipe the part of the housing that the O-ring seals against with a clean lint-free cloth.
6. Re-grease the O-ring with a thin layer of O-ring grease until it appears to be smooth and shiny. Do not over grease it. Use just enough grease so the O-ring will pull smoothly through your fingers. Excessive amounts of grease will only serve to attract dirt to the o-ring.
7. Make sure that the O-ring is properly (evenly) installed in the O-ring groove.
8. To reinstall the clean and lubricated O-ring, place the entire O-ring over the groove and start by pushing the O-ring in at each corner then, push the O-ring at each side and finally, work in the rest of the O-ring. Never start at one end and work your way around the O-ring. This places uneven tension on the O-ring which may cause the O-ring to stretch resulting in excess O-ring, which will have no place to go.

There are internal O-rings on the housing controls as well. These O-rings are not as susceptible to damage as they are not exposed but they do require yearly maintenance and are not user serviceable. The housing should be returned to AQUATICA or to an authorized AQUATICA service facility for this annual maintenance. Check for the closest service center on our website www.aquatica.ca.

An internal moisture alarm is available as an option for your AQUATICA Digital housing (Product # 20023). This moisture alarm is powered by an easily replaced **CR 2032** battery. Please read the instruction sheet provided carefully for your moisture alarm prior to installing the battery.

Technical Lighting Control

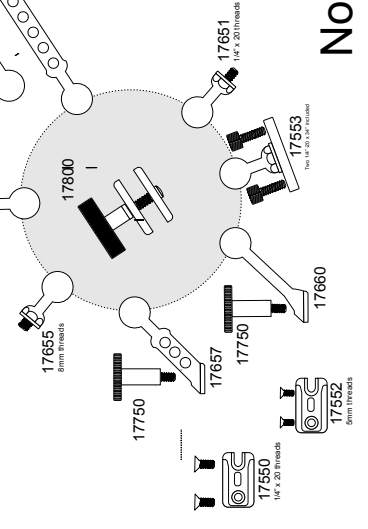
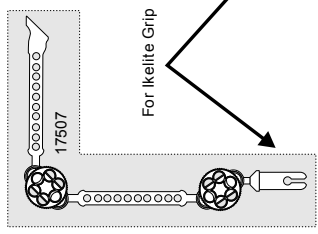
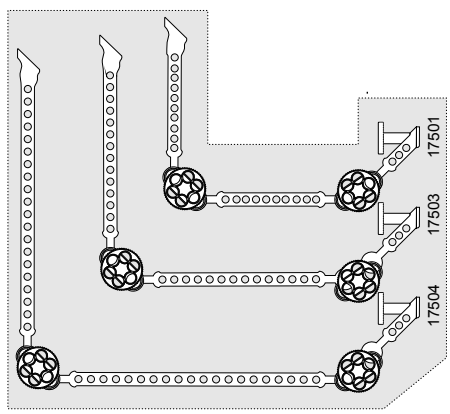
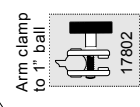
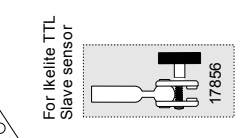
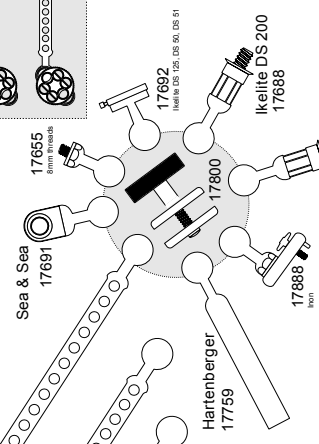
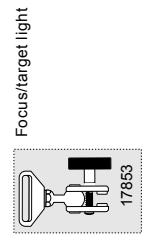
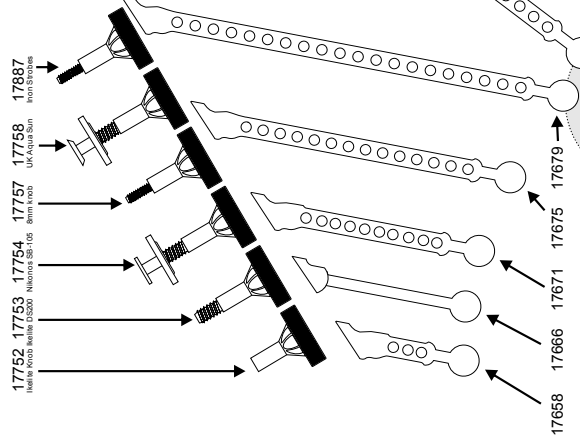
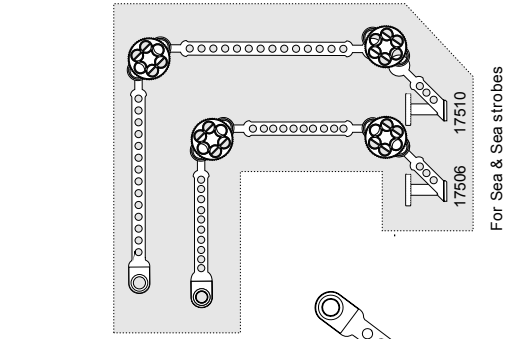
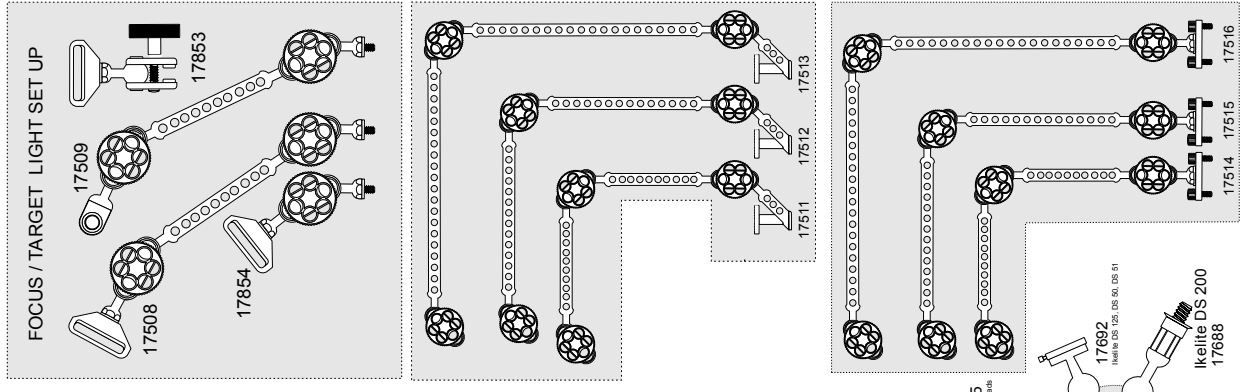

No pins, no O-rings just tough, reliable performance from TLC

AQUATICA^{TM.}

Digital

WARRANTY

PLEASE READ CAREFULLY

One year Limited Warranty.

Thank you for purchasing an AQUATICA manufactured product! Your AQUATICA housing is handcrafted by a small group of specially trained individuals - each of whom takes the most pride and satisfaction in offering you the best underwater camera housings in the world. All AQUATICA products are guaranteed against defects in material or workmanship for (1) one full year from the date of purchase for consumer use. these same products when used commercially will carry a 90-day warranty. No statutory warranty applies. Camera housed in AQUATICA housings are not covered under this warranty and ANY WATER DAMAGE SUSTAINED DUE TO INSTALLATION ERROR OR ANY OTHER REASON IS NOT THE RESPONSABILLITY OF AQUATICA. Therefore the appropriate insurance should be maintained by the user.

Warranty does not apply to replaceable seals or damages to impacts or abrasive surfaces. Warranty applies only to products purchased from authorized AQUATICA dealers and does not extend beyond the original retail purchaser. Unauthorized modifications or repairs will automatically void this warranty. this applies to removal of serial numbers and AQUATICA identification labels.

To obtain service during or after the warranty period **you must notify** AQUATICA at 514-737-9481 and ship BY REGISTERED MAIL (INSURED) **ONLY**, enclosing your proof of purchase to:

AQUATICA
3025 De Baene
Montreal (Quebec)
H4S 1K8

Mark clearly on your package "Canadian goods returned for repair"

Do not ship by any other means.
Unauthorized packages will be refused.

YOUR SERIAL NUMBER _____